

# Automotive sealing systems

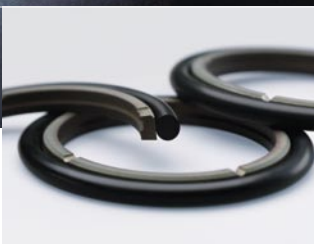

**Your Partner for Sealing Technology**

## Optimum automotive sealing solutions

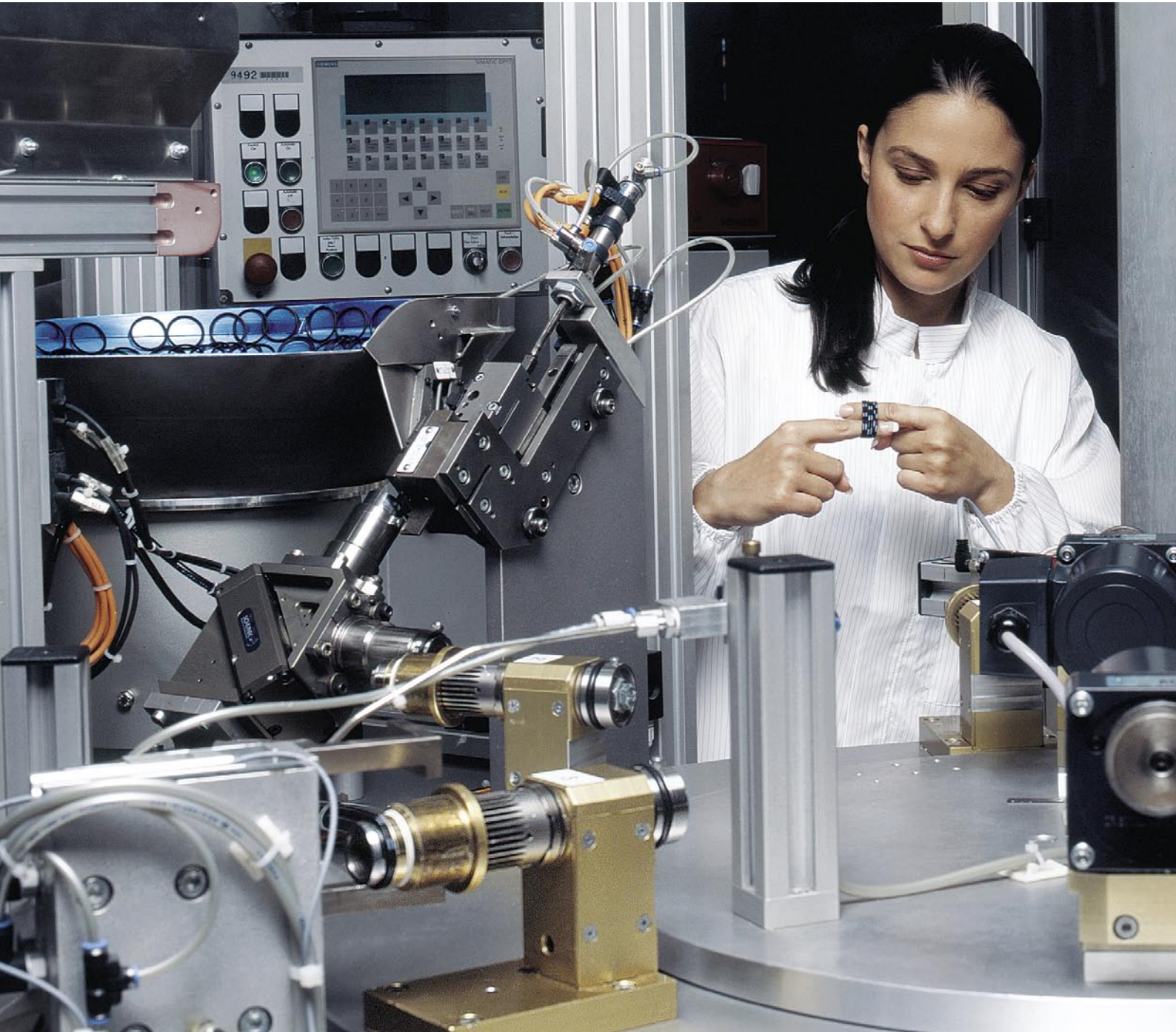

### Engineering partnerships

Safety critical vehicle systems, such as fuelling, braking and steering rely upon sealing solutions of the highest integrity, engineered in partnership with Trelleborg Sealing Solutions.



### Offering long service life

Involved in car and truck seal development for over 50 years, sealing configurations from Trelleborg Sealing Solutions are maximizing service life on most vehicle models on the road.

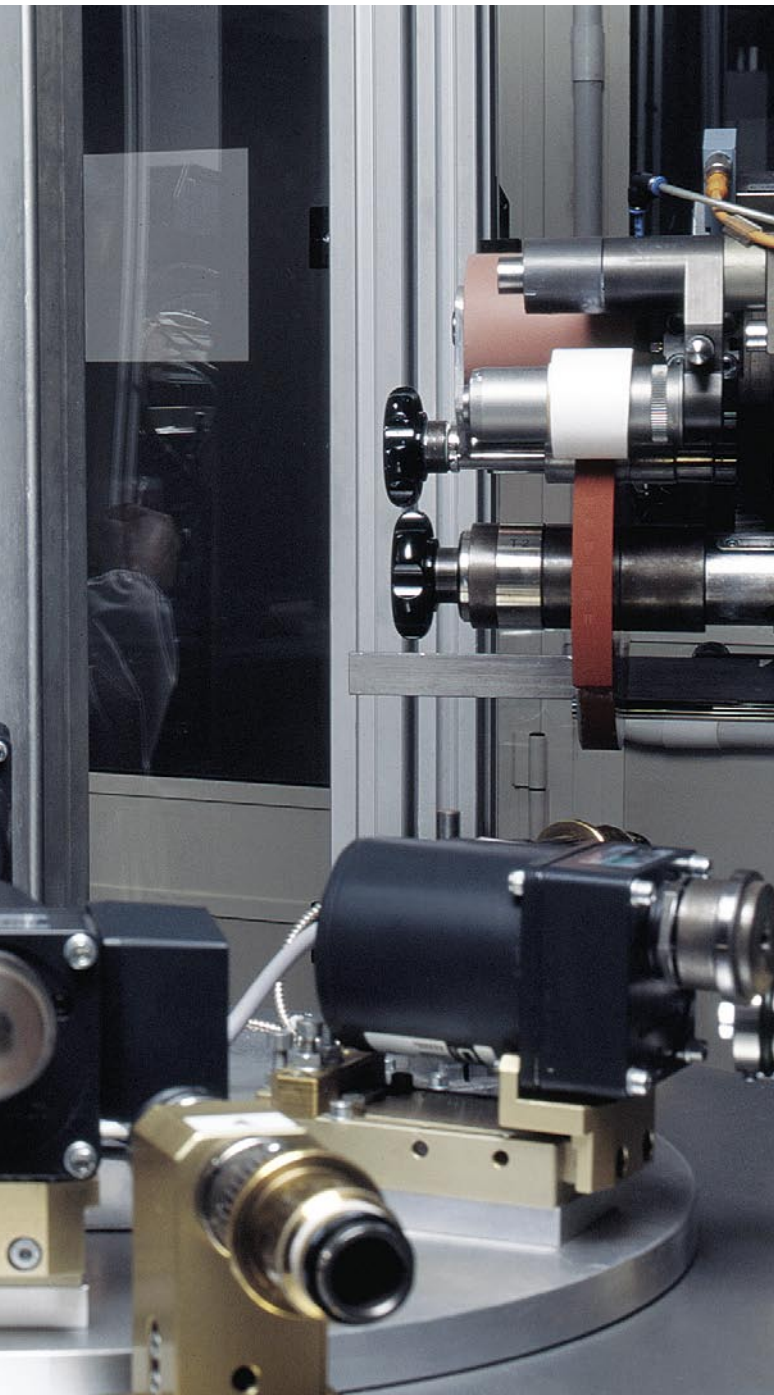

#### **Reliable sealing integrity**

Whatever the application, whether involving a custom design or a standard O-Ring, Trelleborg Sealing Solutions works with customers to offer the optimum seal arrangement.

Trelleborg Sealing Solutions works with automotive customers in development partnerships to satisfy the needs of today while contributing to the development of vehicles for the future. Our sealing solutions are featured on every major system, including fuel systems, emission controls, air induction systems, ride control, air conditioning, engine cooling, steering and braking systems.

#### **Our mission**

Trelleborg Sealing Solutions will be the leading global partner for our customers in selected automotive applications by providing high-performance sealing solutions with excellent quality and service.

#### **An automotive sealing pioneer**

Trelleborg Sealing Solutions has been involved in car and truck seal development for over 50 years and is a major sealing supplier to automotive manufacturers. Trelleborg Sealing Solutions can meet the needs of this growing and changing industry by efficiently supplying cost-effective, innovative solutions that give the highest sealing integrity.

#### **Meeting the demanding sealing challenge**

Seals must stand up to extremes of temperature and pressure, sometimes operate in partial vacuum conditions and withstand possible exposure to the elements. Not only static but moving parts must be sealed, often at high rotational speeds, requiring low friction options. Chemical compatibility of seal materials is a key issue, as components are in contact with a wide range of media that can deteriorate seals, reducing service life.

#### **Specifying the best sealing configuration**

Whether a seal solution involves a custom design or a standard O-Ring, as a principal supplier to most major tier-1 and 2 manufacturers, we are able to work with our customers to offer the best sealing arrangement. These are designed to give excellent sealing integrity, over a long service life, while meeting performance demands. We can select from a unique range that uses our proprietary materials, leading-edge manufacturing methods and patented products.

#### **Products for all market requirements**

The range of products offers:

- Temperature resistance from cryogenic up to 850 °C (1560 °F)
- Compounds with almost universal chemical compatibility and superior resistance to lubricants, fuels, refrigerants and engine coolants
- Excellent thermal stability
- Good mechanical strength
- Low long-term compression set and hysteresis
- Automotive approved materials, products and manufacturing

## Service from concept to delivery

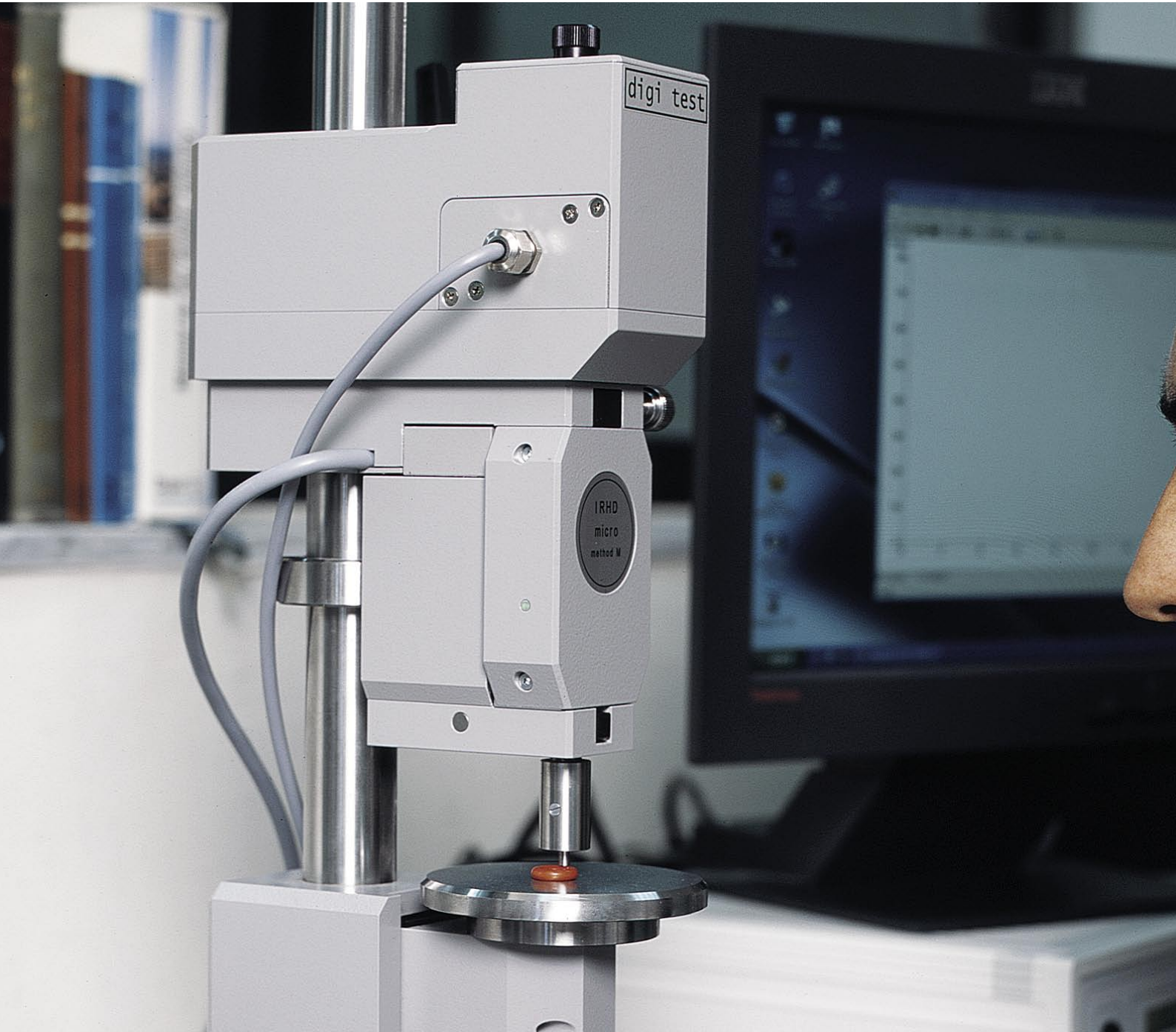

### Products tested to destruction

Significant investment in research and development means products within the unique range from Trelleborg Sealing Solutions, which are often tested to destruction, can go beyond operational requirements.



### Innovative total solutions

Trelleborg Sealing Solutions develops total solutions. This has led to our industry-leading knowledge of coatings technology, focusing on reducing friction both in application and automated assembly.



#### **Global research and development network**

The Trelleborg Sealing Solutions worldwide research and development facilities continuously focus on solutions to match our customers' current and emerging performance standards. They combine their knowledge with that of our manufacturing units, who have experience based on their specialized material or product type. We work with customers on their individual applications, testing solutions on their behalf and if necessary formulating materials or designing products to meet specific needs.

#### **Leading-edge manufacturing capability**

Dedicated automotive production takes place in world-class facilities in Brazil, Denmark, Italy, North America, Malta, Sweden, Poland, United Kingdom, and our growing presence in Asia. We have unrivalled PTFE expertise along with pioneering products and innovative elastomer capabilities and are industry leading in our knowledge of coatings technology.

#### **Sealing expertise throughout the product development process**

The Trelleborg Sealing Solutions service meets and goes beyond industry requirements from product concept to delivery. Customers can benefit from our sealing expertise from initial stages of vehicle engineering through to final build and ongoing aftermarket support. We use state-of-the-art design tools, including customer compatible CAD systems and rapid prototyping, often proving sealing designs in a virtual environment, using techniques such as Finite Element Analysis (FEA).

#### **Servicing and supporting our customers worldwide**

Our international locations allow us to work with design centers in several countries on product specification, then collaborate with manufacturing plants which may be located elsewhere in the world. Effective supply from our regional logistics centers is combined with sub-assembly and Direct Line Feed. Quality is a given and all production sites operate to TS 16949 with a zero defect philosophy.

#### **Environmental Awareness**

Trelleborg Sealing Solutions does its very best in searching for materials and technologies with improved environmental compatibility and in integrating these into production whenever possible. The use of recyclable materials in all of our activities is promoted in the same way, and also the development of procedures that altogether reduce the consumption of material and energy.



#### **Total service capabilities**

Trelleborg Sealing Solutions service reflects and surpasses industry requirements with specialized capabilities exactly matched to the demanding requirements of our customers.

## Technologies matching customer needs

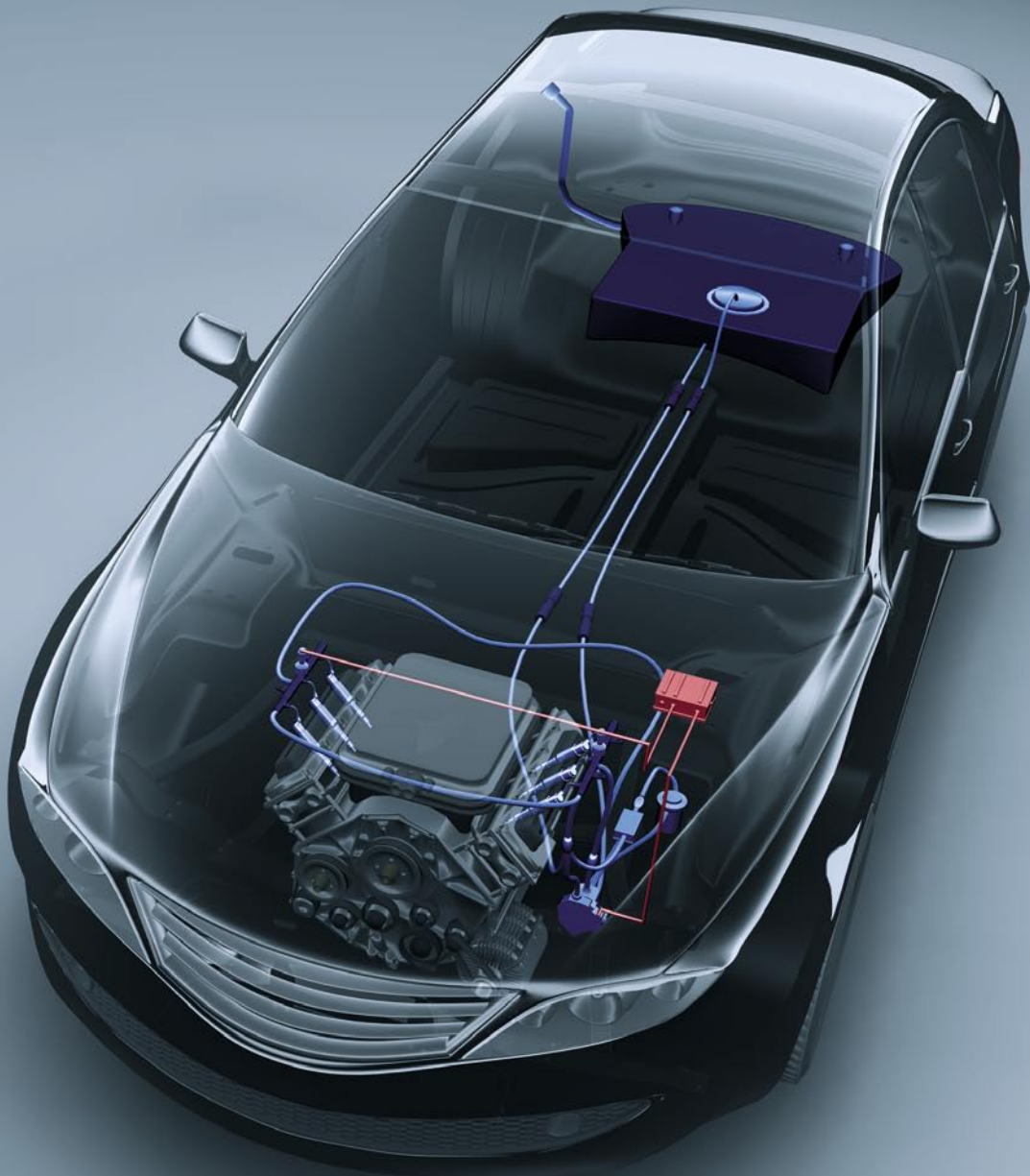

### **O-Rings**

For static applications, any size of O-Ring (standard or custom) is available, in materials ranging from basic elastomer grades to leading-edge, high specification compounds.



### **Advanced elastomers**

Materials used in O-Rings have been specifically developed for the automotive industry. These include conductive elastomers to eliminate static electricity buildup in fuel systems.

**In fuel systems, there are seals at every connection point from the tank, through the pump, on pipes and connectors, to the injectors.**

#### **Constant operation in severe conditions**

Fuel or unit injectors ensure that the engine receives the right amount of fuel. These work constantly when the vehicle is running, so seals that can withstand aggressive environments over the long term are vital.



#### **Solutions to withstand extreme pressures**

To improve performance, pressures in the fuel system are continuously increasing. Seals must operate at extremes, with pressures reaching up to 220 Mpa (2200 bar, 31908 psi) in the latest diesel pumps.

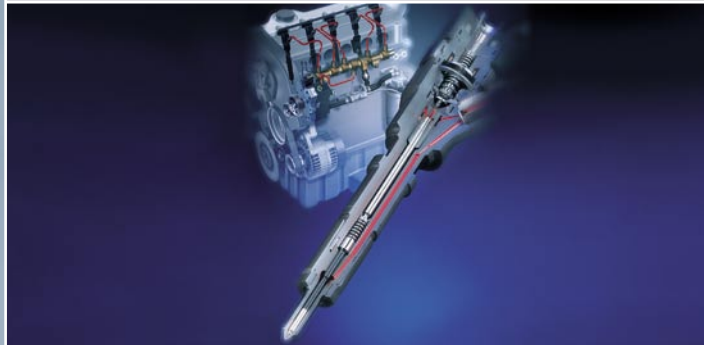

#### **Sealing plastic connections effectively**

Changes in composition of components make sealing more challenging. The use of plastics for fuel rails means seal configurations now need to compensate for greater potential misalignment.



#### **Seals are important in meeting stringent regulations**

On fuel tanks, regulations have influenced the number of inlet and outlet connections, and as each one potentially increases emissions, seals must minimize fuel permeation.

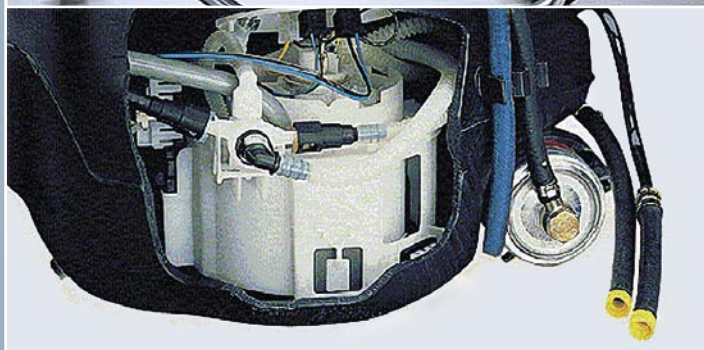

#### **Materials technology**

To maximize service life, materials are engineered to withstand a wide range of aggressive fuels and additives and to be capable of sealing at low and high operating temperatures.

## Innovative custom molded designs

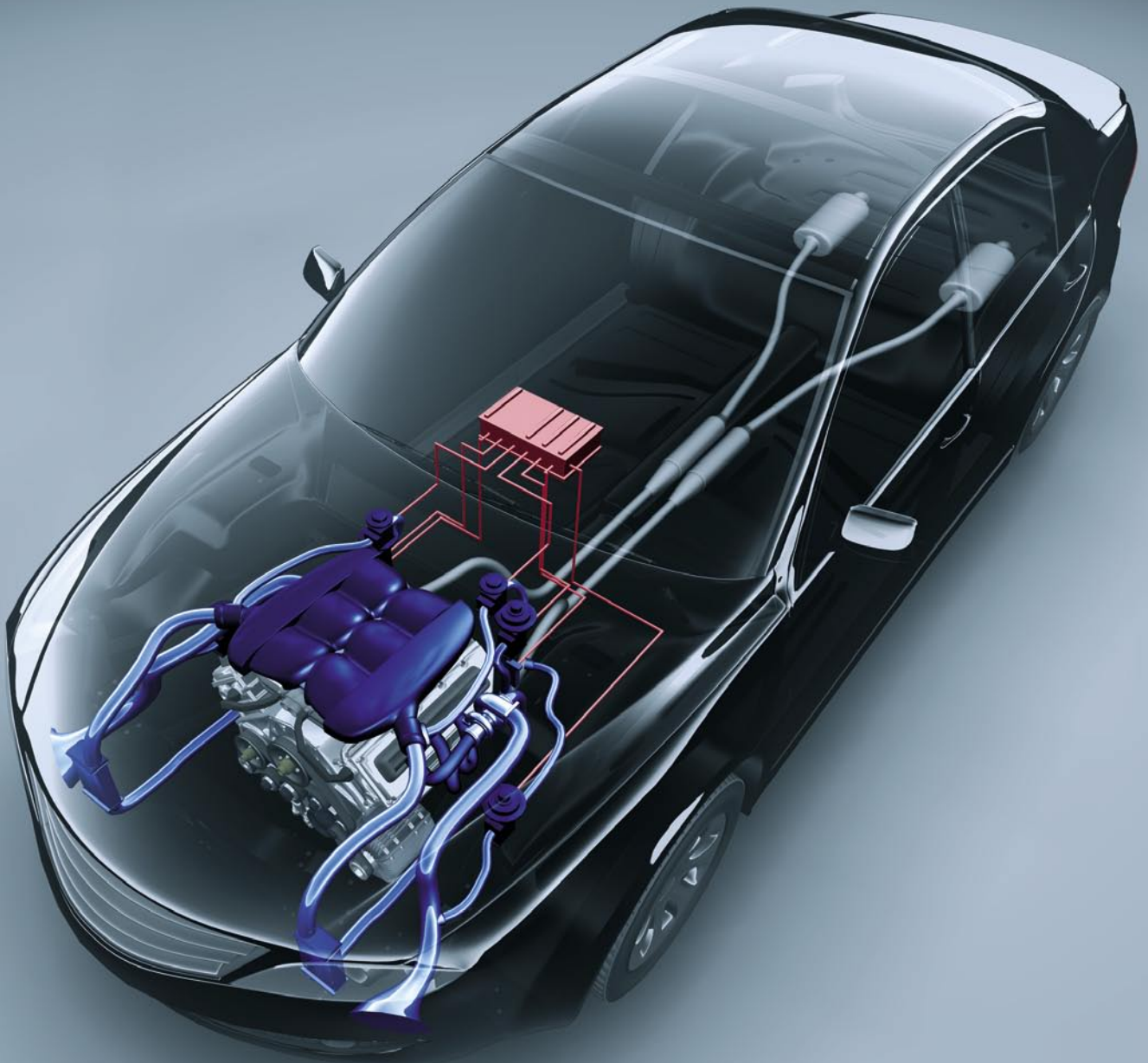

### Custom designed solutions

Most seals supplied to the automotive industry are custom designed. Advanced gaskets are produced in a variety of standard or automotive-specific elastomer materials.

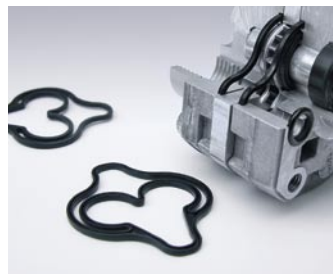

### Tailored Geometries

Unique custom seal designs meeting extreme high temperature and challenging fluid requirements.



**Seals within emission control and air induction systems must give the maximum integrity over a long service life.**

**Minimizing leakage is a priority achieved**

Stringent regulations on vehicle emissions require leakage of vapors to be at an absolute minimum. Diaphragms help achieve this in Exhaust Gas Recirculation valves.

**Sealing from vacuum to backfire pressure**

Air induction systems require sealing solutions engineered to withstand pressures ranging from 85kPa (0.85 bar, 12 psi) running vacuum to 800kPa (8 bar, 116 psi) backfire pressure.

**Compensating for variations in composite components**

Mounting a composite valve to a composite manifold is a sealing challenge. It requires a gasket that compensates for wide tolerances on the faces of both components.

**Excellent solutions for rotary applications**

Superchargers and turbochargers provide the ultimate engine performance. In these, seals must operate at high rotational speeds, where shaft surface speeds can reach 21 m/s (69 ft/s).

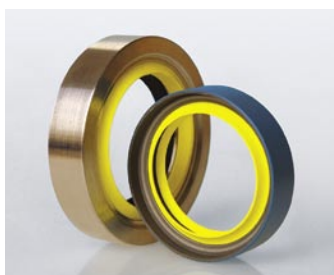
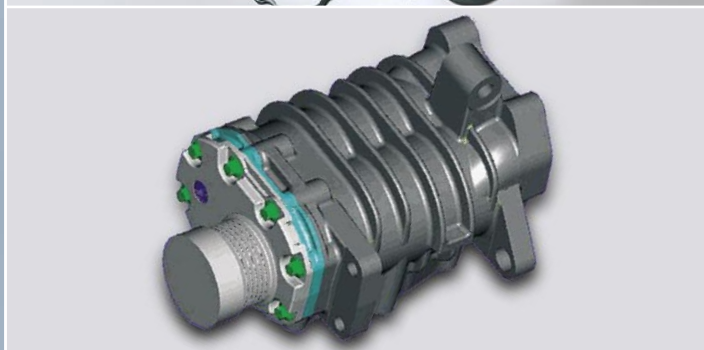
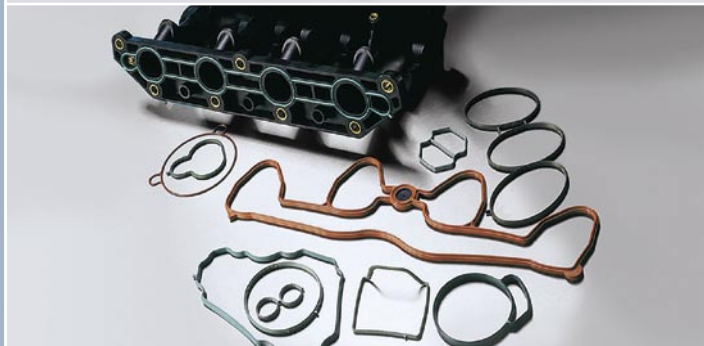
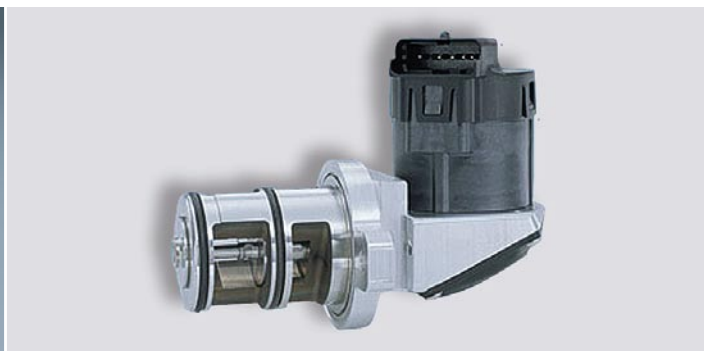

**Rotary sealing**

Varilip® PDR rotary shaft seals, comprised of a Turcon® PTFE sealing lip retained in a crimped or clamped metal case, meet the demands of rotary sealing, especially at high surface speeds.

## Advanced sealing products and materials

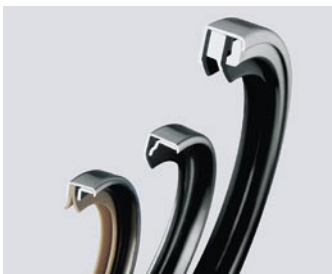
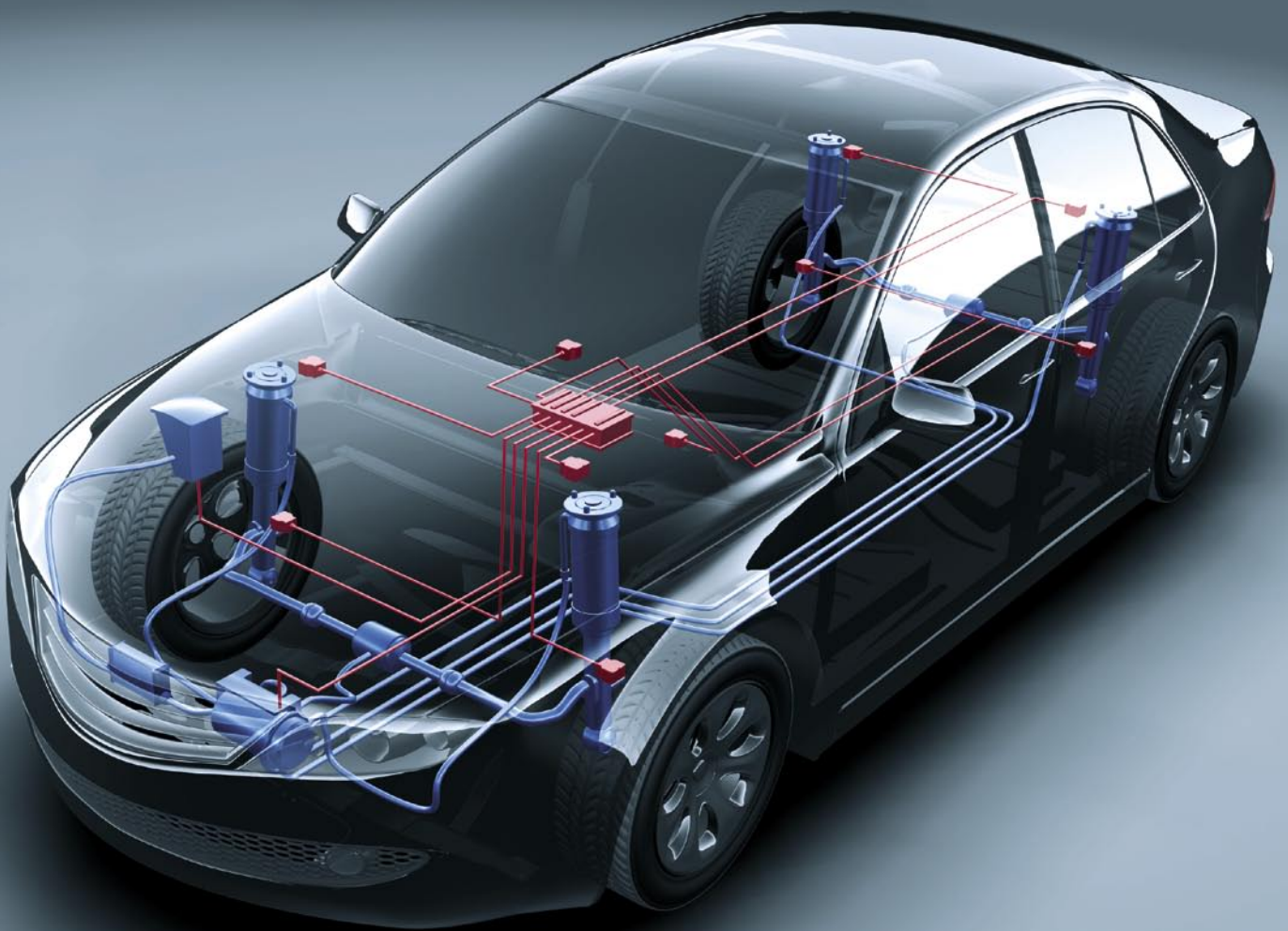

### Unique products

Our proprietary products such as Variseal, spring-energized Turcon PTFE based seals, and Wills Rings, the original metal seal, provide innovative solutions to sealing challenges.



### Stepseal®

Ideal for hydraulic applications is the Stepseal®. It optimizes seal integrity, minimizing the possibility of leakage, and demonstrates excellent friction and anti-extrusion characteristics.

**Trelleborg Sealing Solutions has the superior sealing capabilities required to meet today's ride control and drivetrain needs.**

**Operating in high frequency linear applications**

In ride control systems seals must operate in wide pressure and temperature ranges while demonstrating high chemical resistance. This can be where there is relatively high frequency and surface velocity.



**Exceptional friction characteristics**

Expertise in hydraulic systems allows us to be a major solution provider for 'Active Body Control'. Specially engineered seals give exceptional friction characteristics, optimizing performance.

Anti-Roll system seals increase driver safety and comfort. The special requirements of this application are met with unique products and materials.

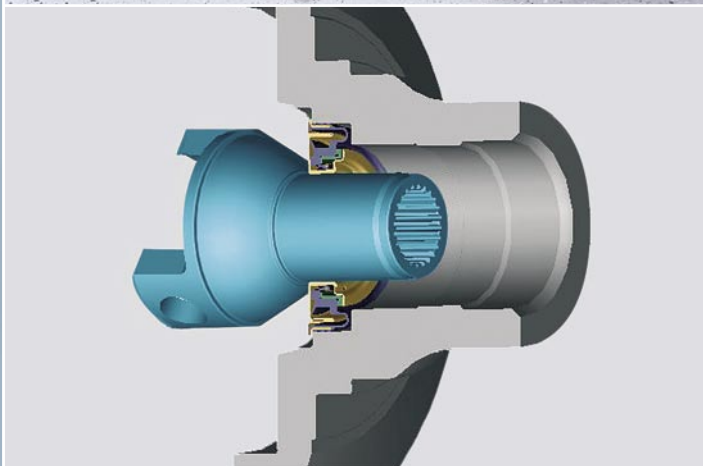

**Dynamic durability performance**

Trelleborg Sealing Solutions provides a total sealing portfolio for the most rigorous applications, from 4WD axle seals to hub seals. We help our customers seal, dampen, isolate, and protect their products. Our ability to utilize elastomers, polymers and metal components makes us the supplier of choice to numerous vehicle manufacturers and tier suppliers.

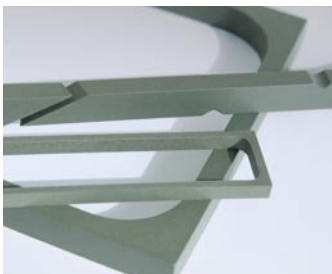

**Vaneseal**

Specifically designed for sealing the vanes in rotary actuators, vaneseals are used in anti-roll systems. Trelleborg Sealing Solutions successfully produces razor sharp corner profiles to ensure effective sealing.

## Expertise to offer unique solutions

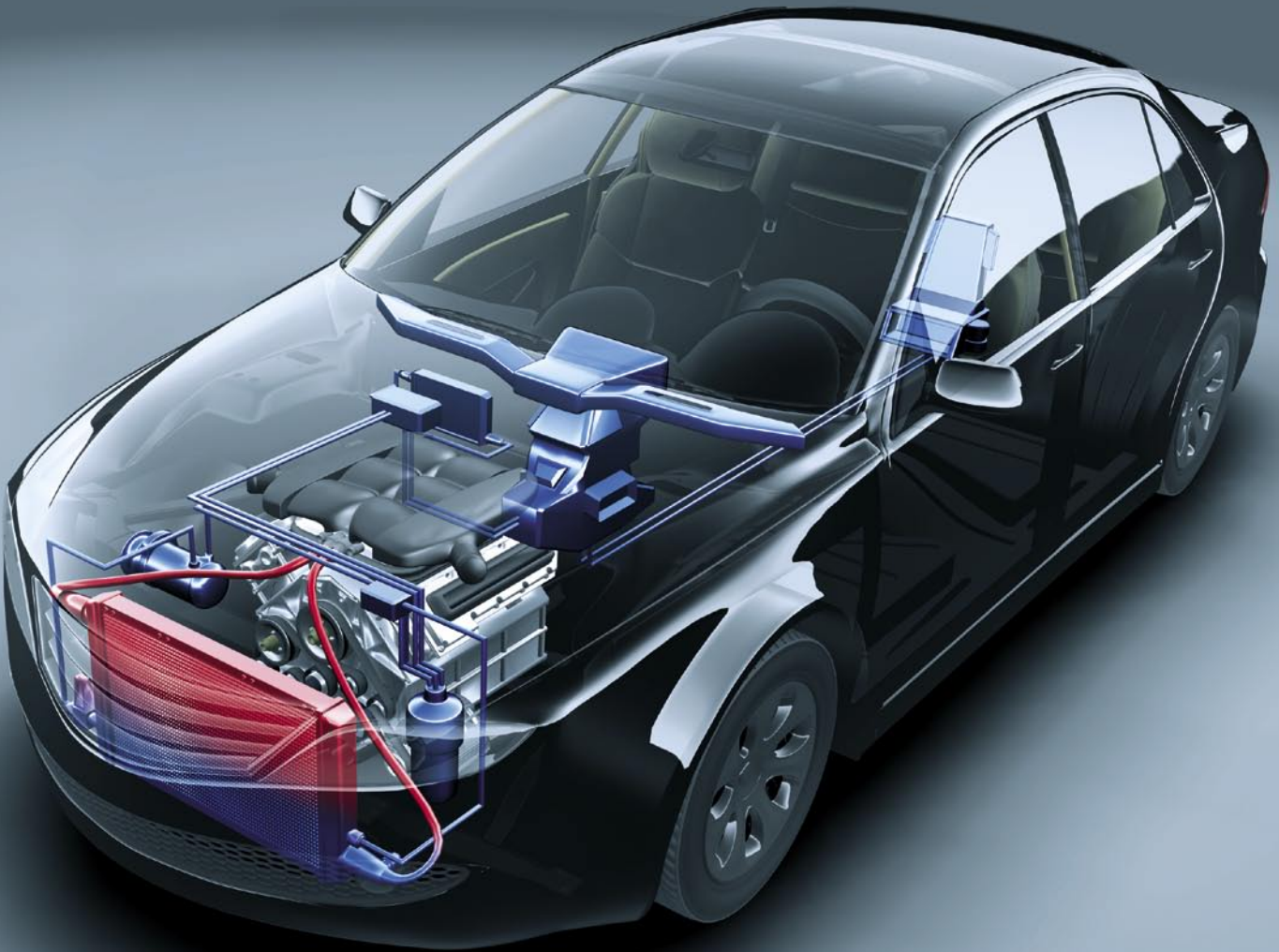

### **Bonded seals**

Trelleborg Sealing Solutions is the original manufacturer of the Dowty bonded seal. These seals are supplied competitively, in high volume, from our low-cost manufacturing bases worldwide for a wide variety of applications.

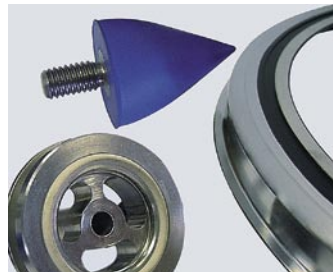

### **Advanced technology**

The expertise of Trelleborg Sealing Solutions in the technology of bonding seals, allows us to offer advanced custom manufactured solutions where elastomers are bonded to both metal and plastics.

**The market for air conditioning, improving driver comfort, is a dynamic and growing sector where new technology means sealing is more complex.**

**Excellent temperature resistance**

Seals must operate at ever more elevated temperatures in cooling systems. Here engine water temperatures are being increased to produce greater oil fluidity, leading to better fuel economy.

**Materials with superior mechanical properties**

The growing use of components manufactured from thermoplastics makes sealing more challenging. For these, high performance materials with good compression stress relaxation characteristics are ideal.

**Fluid sealing**

The fluid transport system is an essential part of an air conditioning system. Making sure that leakage is prevented at every connection point is a design priority. Seals match specific compatibility and operating criteria.

**Exceptional chemical compatibility**

In air conditioning systems, seals need to have good pressure and temperature characteristics and be chemically resistant to refrigerants. For the next generation, they will also be required to perform in CO<sub>2</sub>.

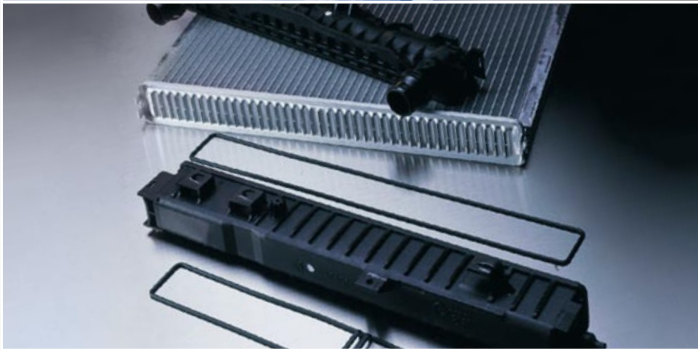

**Optimum sealing choice**

Due to the breadth of range offered by Trelleborg Sealing Solutions, designers can specify seals that meet the challenge of balancing cost effectiveness with performance for all automotive sealing applications.

## Total - Sealing technology



### Extensive test facilities

Strategically-positioned materials and development laboratories and fully resourced design and application centers, continuously deliver innovative sealing solutions.



### Innovative material development

Developing and formulating materials in-house and engaging in ongoing programs of development, Trelleborg Sealing Solutions is also skilled in the field of applied materials technology.



Trelleborg Sealing Solutions is a major international sealing force, uniquely placed to offer a dedicated design and development service for sealing arrangements, from our market leading product and material portfolio; one which has provided solutions that feature in virtually every application conceivable within the aerospace, industrial and automotive industries.

#### **Global - A worldwide presence**

Globally servicing, supporting and supplying our customers, Trelleborg Sealing Solutions has an international network of over 60 facilities worldwide including more than 20 manufacturing sites, strategically positioned materials and development laboratories and fully resourced design and application centers. Facilities are certified to ISO 9001:2000, with many manufacturing sites also working to TS 16949 and VDA 6.1.

#### **Expertise - Our proven capabilities**

With over 50-years experience in developing and applying of sealing systems, Trelleborg Sealing Solutions engineering personnel contribute their knowledge of this specialized technology directly to customers. This includes project management of design, prototyping, production, test and installation using state-of-the-art design tools, fully customer-compatible CAD systems and leading edge Finite Element Analysis (FEA).

#### **Innovation - In materials and supply**

Developing and formulating our materials in-house, Trelleborg Sealing Solutions has acquired significant skills in the field of applied materials technology. Working in close cooperation with worldwide partners, we are engaged in ongoing programs of material and product development, utilizing latest technologies and the resource of our material database, which includes over 2,000 proprietary compounds.

#### **Commitment - To customers' needs long-term**

The aim of Trelleborg Sealing Solutions is to facilitate customers in the achievement of cost effective, durable solutions. We are one of the world's foremost experts in polymer sealing technology. We develop and manufacture safety-critical, polymer-based, precision seals and associated systems.



#### **Superior logistics support**

Trelleborg Sealing Solutions invested in an advanced logistical support system, which effectively delivers products to our customers worldwide from regional warehouses.